



NO NEED FOR
SPRAY FOAM
APPLICATION-
**SAVES
TIME!**

**Check Out Our
New Web Site!**

Therma RIM

Insulated Rim Board

FEATURES

- Easy Energy-Saving solution for difficult to insulate areas
- R-11 Insulation ideal for northern climates
- Factory edge coated for durability and job site protection
- Engineered with dimensionally accurate, APA-Rated Rim Board and OSB bonded with polyisocyanurate foam for maximum thermal efficiency
- Eliminates costly extra trades-Saves Time and Money!

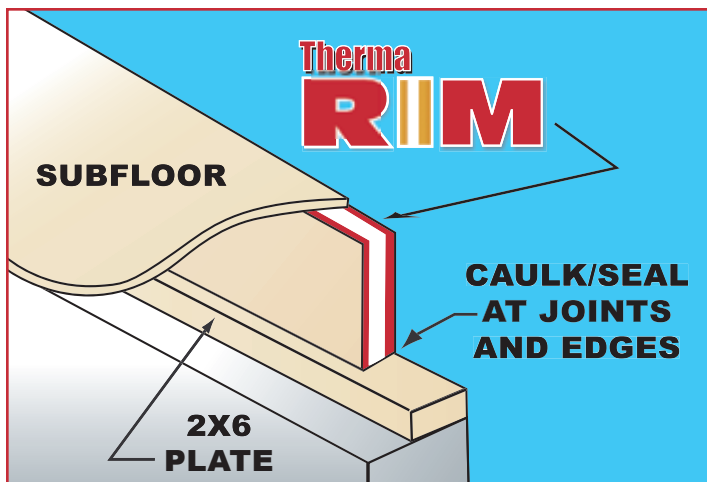

PACKAGE SIZES

3-1/8" X 9-1/2" X 12' (R=11) -
30 pieces/unit

3-1/8" X 11-7/8" X 12' (R=11) -
30 pieces/unit

Contact us for custom sizes for
your project needs!

ThermaRIM



Insulated Rim Board

- ThermaRim Insulated Rim Board and its joining member must have continuous structural support
- A 6" minimum width sill plate is required
- See APA data file for design properties, span lengths and further installation details
- ThermaRim Insulated Rim Board is made with APA Rated Rim Board per standard PRR-401 and is ideal for difficult to insulate areas (prime heat loss areas)
- ThermaRim is designed for rim board and starter joist applications only. Not recommended for use as a structural joist, rafter, header or ledger
- Caulk or seal all connections and joints to minimize heat loss

**MEETS REQUIREMENTS OF
ICC-ES AS124 FOR STRUCTURAL RIM BOARD**

Specifications and size availability subject to change without notice.

TYPICAL ATTACHMENT

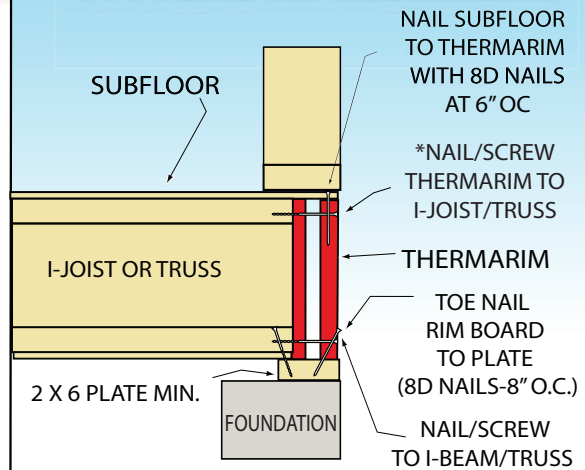

NOTE: JOIST TO PLATE CONNECTIONS AND TEMPORARY BRACING AS REQUIRED BY I-JOIST OR TRUSS MFR'S SPECIFICATIONS

*THERMARIM TO I-JOIST/TRUSS NAIL OR SCREW SCHEDULE

*R-11 3-1/8" THERMARIM -
4-1/2" NAIL OR 4-1/2" #12 SCREW

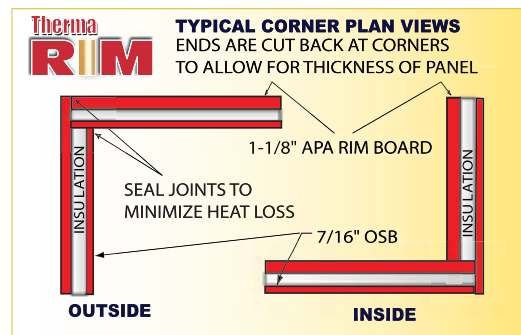

Here's what we are famous for... CORNELL CORPORATION

www.cornellcorporation.com

Performance Roofing Products



Vent-Top ThermaCal

- The largest vent cross section available -10 sq. in. per ft. run
- For Metal or Shingle Roofs

See our Website for Complete Specifications, Downloads and Product Data



Vent-Top ThermaCal

"The Original Ventilated Roof Insulation Since 1987"



ThermaCal All Season Performance

"The Original Nail Base Insulation Since 1979"

CVRS Cornell Ventilated Roof Sheathing

- Both available with Polyiso or XPS Foam
- Fully Machined Panels-Fast Installation!
- Tongue and Groove Foam-Minimum Heat Loss!
- Vent-Top ThermaCal features Industry Leading Airflow with Solid Wood Spacer Construction

- Ready-To-Use Roof Ventilation Solution
- Saves You Time and Money!

CORNELL CORPORATION

P.O. BOX 338 • CORNELL, WISCONSIN 54732
ThermaCal is a Registered Trademark of Cornell Corporation

Tele: 888-439-6411 (Central Time)

Fax: 800-267-8368

Email: cornell@cornellcorporation.com

SOLD BY:

INSULATING AMERICA SINCE 1954!

CORNELLCORPORATION.COM 888-439-6411 FAX 800-267-8368

TRIM-2007-01